

**CLIPSAL**<sup>®</sup>

by Schneider Electric



# Smoke Alarm Isolation Unit 756



Installation Instructions

## 1.0 Introduction

The 756 Smoke Alarm Isolation Unit is a device which connects to Clipsal Firetek® 755 Series Smoke Alarms. The unit provides a set of isolated, normally open (N.O.) and normally closed (N.C.), changeover contacts permitting auxiliary devices such as sirens, strobes and/or security systems to be activated when the new 755 Smoke Alarm is in the alarm state.

The 756 may be used to provide connection of the 755 Smoke Alarm output to an external siren or strobe. It may also be used as an interface to Clipsal C-Bus®, Clipsal HomeSafe Security Systems, emergency lighting or other service.

The 756 is capable of operating correctly in the absence of mains supply and derives its power from the smoke alarm only when the smoke alarm is in the alarm state.

## 2.0 Technical Specifications

Changeover Contacts:	1 x Normally Open (N.O.) 1 x Normally Closed (N.C.)
Contact Rating:	10A resistive and inductive, 250V a.c. 50Hz.
Interconnection Input:	6V to 10V d.c. referenced to Neutral.
Supply Current:	Alarm mode - 1mA minimum. Non-alarm mode (standby) - N.A.
Maximum number of smoke alarms interconnected to a single 756 Isolation Unit:	40 NOTE: Refer to table on page 7 if more than one Isolation Unit is required to be connected.
Switching Delay: (One only smoke alarm)	Turn On - typically 20 seconds on application of interconnect input voltage. Turn Off - typically 3 seconds on removal of interconnect input voltage.  NOTE: Longer turn on delay times may be experienced depending upon how many smoke alarms are interconnected with the Isolation Unit.
Cables Accommodated:	2 x 2.5mm <sup>2</sup> per terminal.
Electrical Safety Isolation:	4kV between input and changeover contacts.
Operating Temperature Range:	0°C to 50°C (ambient).

### 3.0 Installation (For connection with 755 Smoke Alarms)

The 756 Smoke Alarm Isolation Unit requires only two connections to be made to the smoke alarm. These are to the Interconnect and Neutral terminals. A Loop terminal has also been provided on the input side of the Isolation Unit. The Normally Open (N.O.) and Normally Closed (N.C.) contact terminals may then be wired to an auxillary device requiring switching/triggering when the smoke alarm is activated.

240V a.c. installation must be carried out by a licensed electrician or similarly qualified personnel in accordance with the SAA Wiring Rules (AS/NZS3000).

Prior to wiring the 756 Isolation Unit, it is recommended that the electronic circuit board be removed from the enclosure and that the enclosure base be fixed to a suitable mounting surface. This will ensure that the delicate electronic circuitry of the 756 does not become accidently damaged when mounting the base.

When wiring has been completed, the adhesive tape backing may be removed from the bottom of the electronic circuit board and the board attached to the mounting base. The cover enclosure may then be attached to the mounting base which will in turn secure the internal electronic circuitry and wiring. (Note: It will be necessary to cut out appropriate cable entry holes at either end of the enclosure prior to attaching the cover to the base.)

**WARNING:** Exercise care when handling the printed circuit board, in order to prevent accidental damage by means of electrostatic discharge. Such damage is expressly excluded form the warranty provisions for the product.

## 4.0 Wiring Diagram

- Wiring to the Neutral and Interconnect terminals must be performed using 1.5mm<sup>2</sup> minimum solid or stranded cable with a rating of 240V.
- Recommended stripping length of cables is 8.5mm.
- Devices connected to the switched output terminals will need to be wired using cables of appropriate colour, insulation thickness and cross sectional area, complying with any technical requirements of the installation and the requirements of any regulatory authority.
- Figure 1 illustrates the internal block diagram for the 756 and highlights the changeover switch contact arrangement.

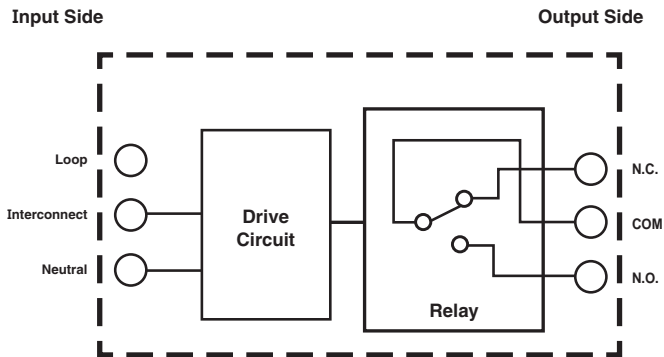

Figure 1: 756 Internal Block Diagram

- Figure 2 illustrates the wiring diagram for connection of the 756 Isolation Unit to a single 755 Series Smoke Alarm. For connecting the Isolation Unit to any other type or model of smoke alarm please consult your nearest Clipsal Representative.

**Fuse or  
Circuit  
Breaker**

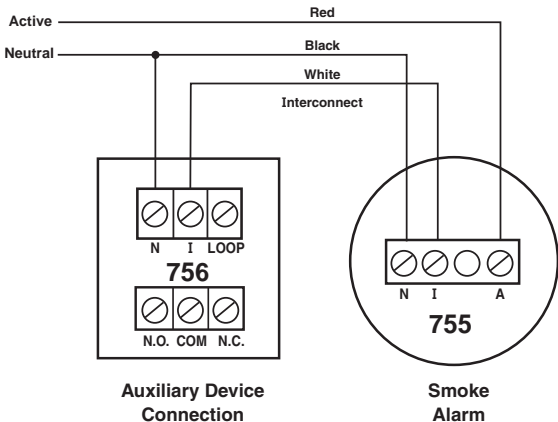

Figure 2: Connection to a single 755 Series Smoke Alarm

- Figure 3 illustrates the wiring diagram for connection of the 756 Isolation Unit to multiple 755 Series Smoke Alarms.

**Fuse or  
Circuit  
Breaker**

**Active  
Neutral**

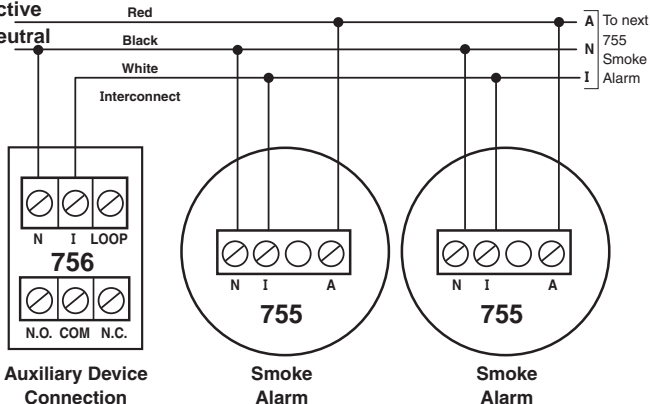

Figure 3: Connection to multiple Series 755 Smoke Alarms

- The 756 Isolation Unit may be connected to as many as 40 Clipsal Firetek® 755 Smoke Alarms. If more than one Smoke Alarm Isolation Unit is required to be connected to an installation, refer to the table below which specifies the maximum number of smoke alarms that can be connected to the Isolation Units.

Number of 756 Isolation Units	Number of 755 Smoke Alarms allowable
1	up to 40
2	up to 28
3	up to 16
4	up to 6

**WARNING:** Connection of the INTERCONNECT terminal to a 240V Active mains supply will damage the Isolation Unit and void the warranty. Such action may also damage any/all Interconnected Smoke Alarms, and will also void applicable warranty.

## 5.0 Testing

- Testing may be performed as soon as all of the connections have been made to the 756 Isolation Unit and Smoke Alarm(s).
- Ensure that the mains is switched off.
- Check that a fresh 9V battery is fitted to your smoke alarm(s). Unless a 9V battery is installed to your smoke alarm, disconnection of mains power will render the 756 Isolation Unit inoperative.
- The Smoke Alarm Isolation Unit may be tested by pressing the HUSH/TEST button on the 755 Smoke Alarm. (Note: If more than one smoke alarm is connected it is recommended that the furthest smoke alarm from the Isolation Unit is used for performing this test.) The Smoke Alarm Isolation Unit should activate the device connected to the changeover contact terminals within approximately 20 seconds of the smoke alarm siren sounding.
- Restore mains power to the smoke alarm(s) and Isolation Unit and repeat test number 4.
- It is recommended that the above test be performed at least once a month to ensure that the installation is operating correctly.
- If the Isolation Unit fails to operate in any of the above tests, check the wiring, 9V battery, fuses or circuit breaker.

**NOTE:** Be aware - the default contact state (N.O.) may have changed due to shock/vibration experienced during transport. This is easily rectified. Simply connect the unit and initiate testing as described above. Be sure to press and hold the Test Button for at least 20 seconds. Upon release of the Test Button, the contact status will be restored to the Normally Open (N.O.) position.

## 6.0 Warranty

1. The benefits conferred herein are in addition to, and in no way shall be deemed to derogate; either expressly or by implication, any or all other rights and remedies in respect to the Clipsal Product, which the consumer has under the Commonwealth Trade Practices Act or any other similar State or Territory Laws.
2. The warrantor is Clipsal Australia Pty Ltd of 33 - 37 Port Wakefield Road, Gepps Cross, South Australia 5094. Telephone (08) 8161 0511. With registered offices in all Australian States.
3. This Clipsal Product is guaranteed against faulty workmanship and materials for a period of two (2) years from the date of installation. Warranty excludes any user replaceable parts, in particular lamps and glass panels. No liability is accepted in relation to discolouration of plastic or painted parts.
4. Clipsal Australia Pty Ltd reserves the right, at its discretion, to either repair free of parts and labour charges, replace or offer refund in respect to any article found to be faulty due to materials, parts or workmanship.
5. This warranty is expressly subject to the Clipsal Product being installed, wired, tested, operated and used in accordance with the manufacturer's instructions.
6. All costs of a claim shall be met by Clipsal Australia Pty Ltd, however should the product that is the subject of the claim be found to be in good working order all such costs shall be met by the claimant.
7. When making a claim the consumer shall forward the Clipsal Product to the nearest office of Clipsal Australia Pty Ltd with adequate particulars of the defect within 28 days of the fault occurring. The product should be returned securely packed, complete with details of the date and place of purchase, description of load, and circumstances of malfunction.



---

### Clipsal Australia Pty Ltd

A member of Schneider Electric

[clipsal.com](http://clipsal.com)

Contact us: [clipsal.com/feedback](http://clipsal.com/feedback)

National Customer Care Enquiries:

**Tel 1300 2025 25      Fax 1300 2025 56**

Clipsal Australia Pty Ltd reserves the right to change specifications, modify designs and discontinue items without incurring obligation and whilst every effort is made to ensure that descriptions, specifications and other information in this catalogue are correct, no warranty is given in respect thereof and the company shall not be liable for any error therein.

© Clipsal Australia Pty Ltd. The identified trademarks and copyrights are the property of Clipsal Australia Pty Ltd unless otherwise noted.